



Shanghai Ebasee Electric Co.,Ltd
 Add: No.18 Gutang Road, Pudong,
 Shanghai,201209 P.R.China

Tel: +86 21 50320898
 Fax: +86 21 50320828
 http://www.ebasee.com

MCCB Isolator	B Rear panel wiring dimension								
	A1	B	B1	H	H1	Φd	Φd1	Φd2	
EBS9M-125C	25	114	111	62	87	6	14	5	
EBS9M-125S	25	114	111	62	87	6	14	5	
EBS9M-160C	30	134	132	72	112	8	18	5	
EBS9M-160S	30	134	132	72	112	8	18	5	
EBS9M-160M	30	134	132	72	112	8	18	5	
EBS9M-300C	35	144	126	87	126	12	24	5	
EBS9M-300S	35	144	126	87	126	12	24	5	
EBS9M-300M	35	144	126	87	126	12	24	5	
EBS9M-630C	44	230	194	83	136	18	35	7	
EBS9M-630S	44	230	194	83	136	18	35	7	
EBS9M-630H	44	230	194	83	136	18	35	7	
EBS9M-800S	70	243	243	174	243	26	48	7	
EBS9M-800H	70	243	243	174	243	26	48	7	

MCCB Isolator	C Front panel wiring dimension		
	Φd3	A4	B4
EBS9M-125C	5	25	111
EBS9M-125S	5	25	111
EBS9M-160C	5	30	132
EBS9M-160S	5	30	132
EBS9M-160M	5	30	132
EBS9M-300C	5	35	126
EBS9M-300S	5	35	126
EBS9M-300M	5	35	126
EBS9M-630C	7	44	194
EBS9M-630S	7	44	194
EBS9M-630H	7	44	194
EBS9M-800S	7	70	243
EBS9M-800H	7	70	243



EBS9M

MCCB ISOLATOR USER'S MANUAL

Standard accessories & necessary tools

Standard accessories

Model	Poles	Bolt		Nut		Insulation barrier
		Type	QTY	Type	QTY	
EBS9M-125	3P	M4 x 55	2			4
	4P	M4 x 55	4			6
EBS9M-160	3P	M4 x 40	2			4
	4P	M4 x 40	4			6
EBS9M-300	3P	M4 x 60	2			4
	4P	M4 x 60	4			6
EBS9M-630	3P	M6 x 60	4	M6	4	4
	4P	M6 x 60	4	M6	4	6
EBS9M-800	3P	M6 x 40	4	M6	4	4
	4P	M6 x 40	4	M6	4	6

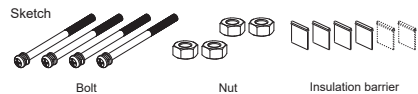

Necessary tools

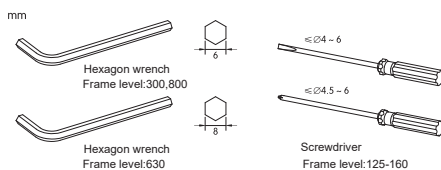

Outline and dimension (mm)

A Outline

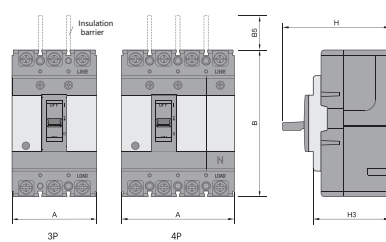

B Rear panel wiring dimension

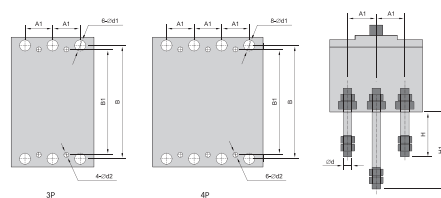

C Front panel wiring dimension

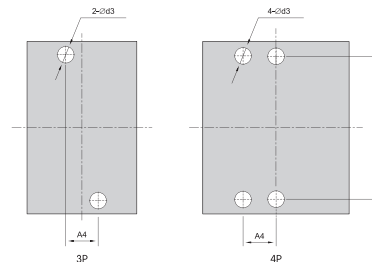

D Plug-in wiring dimension

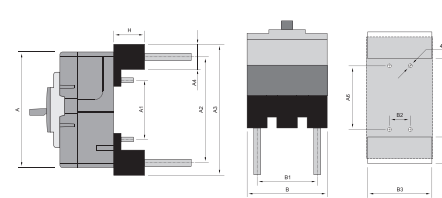

Model

MCCB Isolator	A Outline					
	3P	4P	B	B5	H	H3
EBS9M-125C	75	100	130	50	94	68
EBS9M-125S	75	100	130	50	94	68
EBS9M-160C	90	120	155	50	94	68
EBS9M-160S	90	120	155	50	94	68
EBS9M-160M	90	120	155	50	109	83
EBS9M-300C	105	140	165	100	96	68
EBS9M-300S	105	140	165	100	96	68
EBS9M-300M	105	140	165	100	119	91
EBS9M-630C	140	185	257	110	159	105
EBS9M-630S	140	185	257	110	159	105
EBS9M-630H	140	185	257	110	159	105
EBS9M-800S	210	280	275	110	159	104
EBS9M-800H	210	280	275	110	159	104

MCCB Isolator	D. Plug-in wiring dimension													
	A	A1	A2	A3	A4	A5	A6	A7	H	B	B1	B2	B3	Φd
EBS9M-125C	130	54	114	140	29	31	54	80	48	75	50	25	78	5.2
EBS9M-125S	130	54	114	140	29	31	54	80	48	75	50	25	78	5.2
EBS9M-160C	155	54	134	168	38	40	54	92	52	90	60	30	93	6.5
EBS9M-160S	155	54	134	168	38	40	54	92	52	90	60	30	93	6.5
EBS9M-160M	155	54	134	168	38	40	54	92	52	90	60	30	93	6.5
EBS9M-160M	155	54	134	168	38	40	54	92	52	90	60	30	93	6.5
EBS9M-300C	165	54	144	182	45	47	54	90	30	105	70	70	108	6.5
EBS9M-300S	165	54	144	182	45	47	54	90	30	105	70	70	108	6.5
EBS9M-300M	165	54	144	182	45	47	54	90	30	105	70	70	108	6.5
EBS9M-630C	257	140	230	282	55	55	140	171	60	134	87	44	136	8.2
EBS9M-630S	257	140	230	282	55	55	140	171	60	134	87	44	136	8.2
EBS9M-630H	257	140	230	282	55	55	140	171	60	134	87	44	136	8.2
EBS9M-800S	275	155	243	298	55	56	155	187	60	206	140	70	208	8.2
EBS9M-800H	275	155	243	298	55	56	155	187	60	206	140	70	208	8.2

A. Operational testing

Test preparation

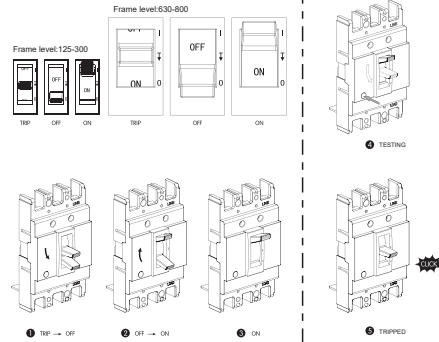

B. Internal accessories & mounting

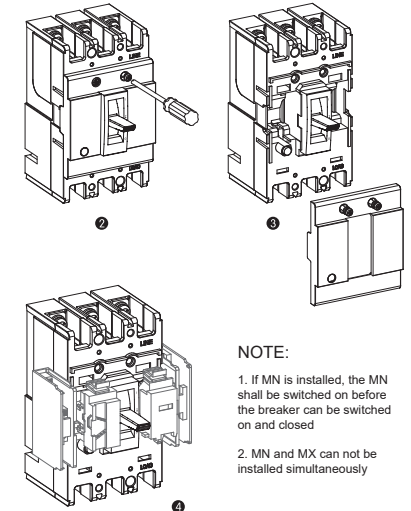
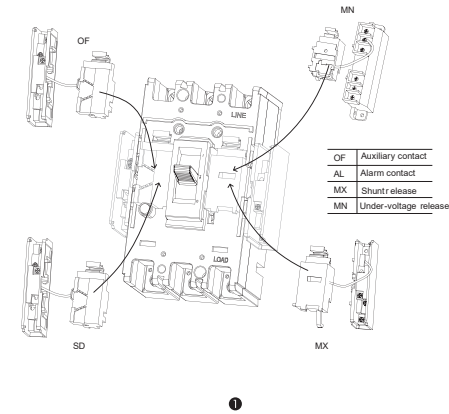

7

8

9

10

C. Wire

mm

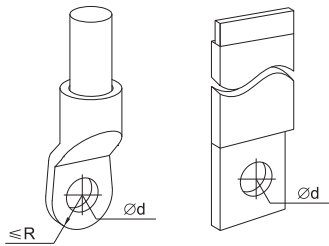

Model	size of wire	
	Φd	R
EBS9M-125	8.5	8
EBS9M-160	8.5	8.5
EBS9M-300	10.2	10.5
EBS9M-630	14.2	13
EBS9M-800	630A	16.2
	800A	18.2

11

D. Mounting of circuit breaker

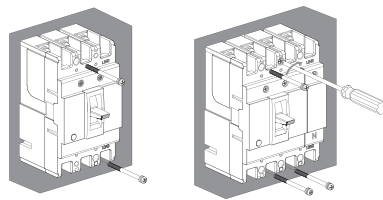

E. Wiring

Note: Incoming and outgoing lines can be reversely connected as required

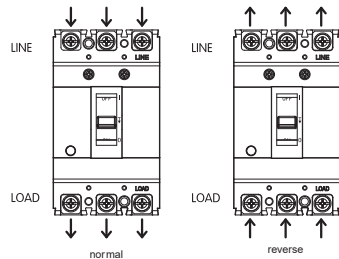

12

F. Wire connection

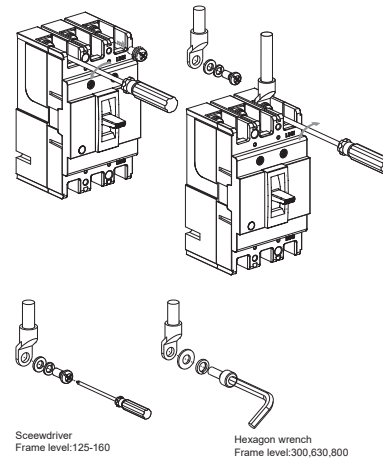

13

G. Mounting insulation barrier

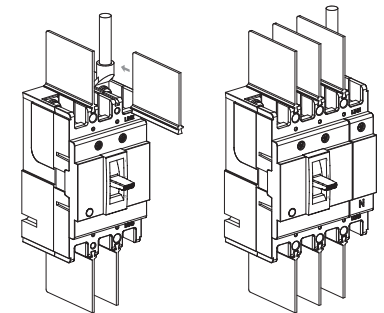

14